

**HYGIENIC  
CLAMPS**  
ASME VIII PRESSURE VESSEL

<b>Material</b>	316 / 1.4401
<b>Application</b>	Pressure Vessel
<b>Hinge Lay-Out</b>	Hinge Plate & Safety Bolt

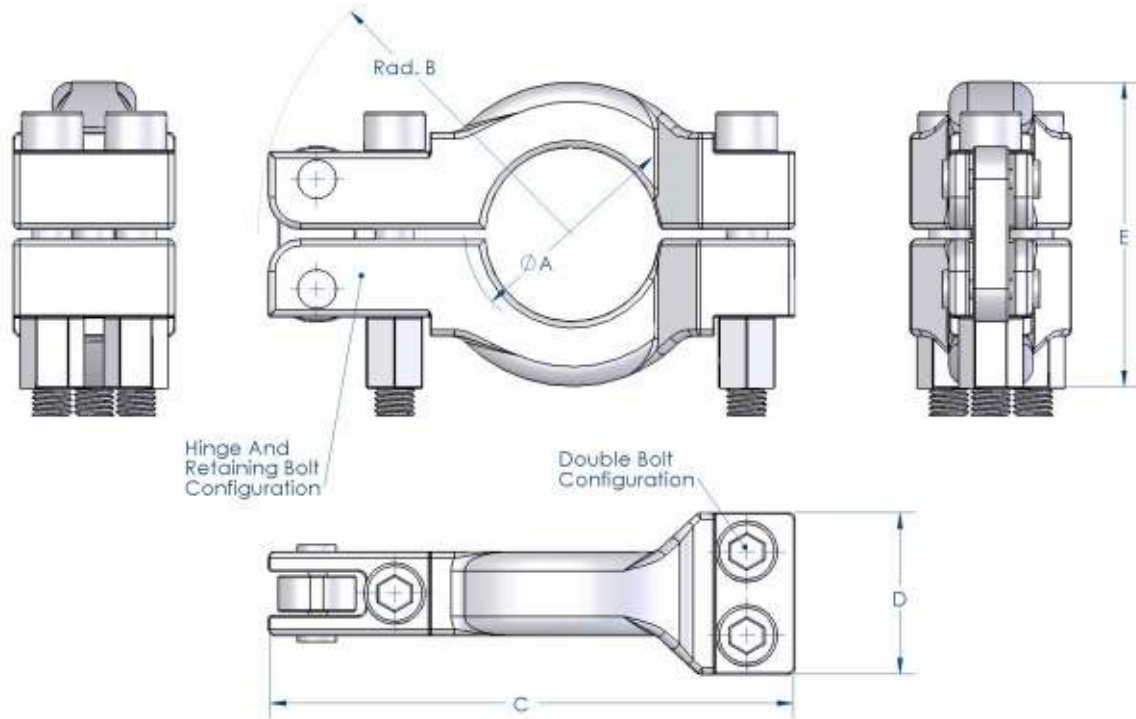

ASME VIII CLAMPS							
Nominal Clamp Sized	Dimensions (mm)					Mass (Kg)	Ordering Codes ASME VIII
	Flange ØA	Rad B	Length C	Length D	Length E		
1" - 1 1/2"	50.5	85.0	145.0	50.0	80.0	1.80	C010.6.ASME
2"	64.0	97.0	163.0	50.0	94.0	1.96	C020.6.ASME
3"	91.0	115.0	203.0	50.0	124.0	3.20	C030.6.ASME
4"	119.0	135.0	233.0	50.0	160.0	3.68	C040.6.ASME
6"	167.0	160.0	281.0	50.0	206.0	4.70	C060.6.ASME
6 5/8"	183.0	170.0	300.0	50.0	222.0	4.98	C066.6.ASME
8"	217.0	185.0	333.0	50.0	258.0	5.45	C080.6.ASME
10"	268.0	210.0	385.0	50.0	308.0	6.30	C100.6.ASME
12"	319.0	235.0	433.0	50.0	358.0	7.02	C120.6.ASME

L.J. STAR INCORPORATED  
P.O. Box 1116 \* Twinsburg, OH 44087  
Tel: 330/405-3040 | Fax: 330/405-3070  
e-mail: view@ljstar.com  
website: www.ljstar.com

