

Lumiglas Sight glass wiper with flexible drive SW II BW

for use with circular sight glass assemblies to DIN 28120 or similar

Mounting:

By means of pressure tight glands through both base and cover flange of sight glass assembly; suitable for sight glass discs corresponding to DIN 7080 or DIN 8902.

Application:

For manually activated cleaning, when required, of inside face of glass in sight ports. Particularly suitable for pressure and vacuum, vessels requiring test certification both in **explosion hazardous as well as non hazardous** operating areas.

The glass discs fitted into the assemblies correspond to DIN 7080 or DIN 8902 standards.

Suitable for circular sight glass assemblies nominal size DN 100 ... DN 200.

Operating Conditions:

Vacuum tight; pressure tight to 235 psi (16 bar).

Max. permissible temperature: 428°F (220°C) (depending, however, on type of glass disc used).

Possible Combinations:

Combined fittings of Lumiglas luminaire, flame proof or standard design, is possible with the wiper SW II BW, as is the fitting of a spray device.

Certification/Testing:

Test certificates issued by the state material testing authority Nordrhein Westfalen, Dortmund, are available.

Assembly/Materials Alternative for the complete supply:

Wiperblade: PTFE or silicone rubber

All metal product contact parts are of stainless steel

Mechanical drive internal seal: PTFE



Lumiglas SW II BW mounted into sight glass fitting DIN 28120

Assembly and Installation Instructions:

The wiper is actuated by flexible shaft which engages at one end in the wiper blade holder and at the other in a lever operated ratchet drive mechanism which ensures drive shaft is always rotated in same direction.

A separate set of detailed installation instructions is included in the supply.

A complete sight glass assembly with the wiper SW II BW will include the additional machining of the base will be carried out by manufacturer.

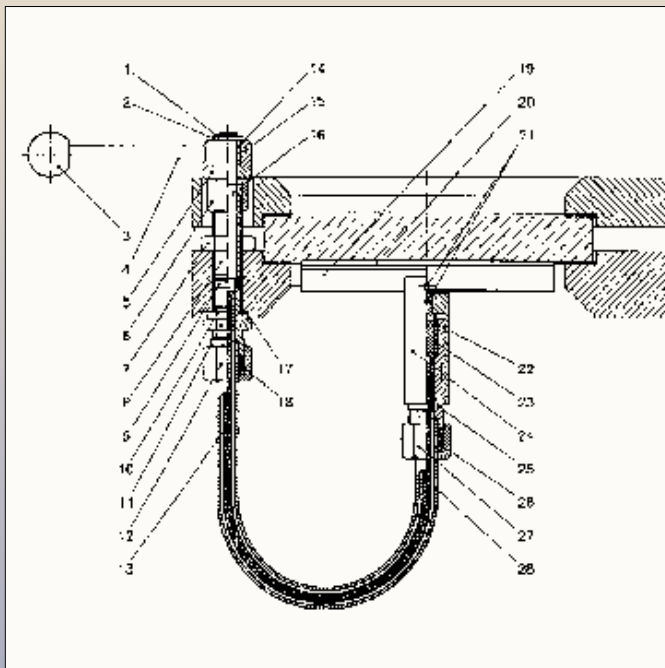

Item Part

- 1 Locking circlip 1.4568
- 2 Washer A2
- 3 Actuating knob (brass insert)
- 4 Ratchet drive lever arm 1.4305
- 5 Spacer ring 1.4305
- 6 Cap nut. Zn8c
- 7 Locknut A4
- 8 Threaded bush 1.4301
- 9 Packing ring PTFE
- 10 Gasket PTFE
- 11 Tube securing bush 1.4571
- 12 Compression nut 1.4571
- 13 Flexible drive shaft 1.4310 or 1.4401
- 14 Ratchet drive unit steel

Item Part

- 15 Drive boss 1.4305
- 16 Shaft drive shank 1.4305
- 17 Washer galvanized steel
- 18 Compression taper ring 1.4571
- 19 Wiper blade holder 1.4571
- 20 Wiper blade silicone or PTFE
- 21 Roll pin 1.4571
- 22 Wiper arm axle 1.4571 or 1.4401
- 23 Coil spring 1.4310
- 24 Wiper carrier shroud 1.4571 or 1.4401
- 25 Guide spigot 1.4571 or 1.4401
- 26 Compression taper ring 1.4571
- 27 Compression nut 1.4571
- 28 Guide tube 1.4571

Dimensions for Lumiglas sight glass SW II BW:

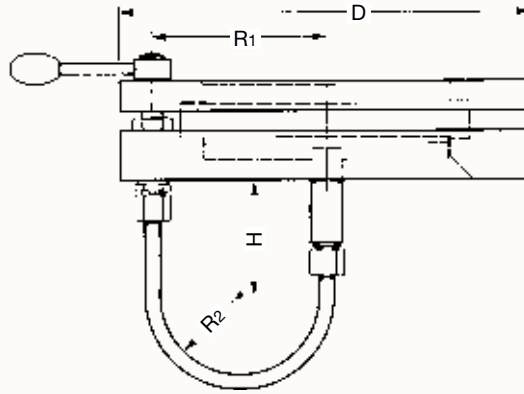

Size		1	2	3	4
nominal bore assembly	DN	100	125	150	200
for viewing diameter	d1	125	150	175	225
flange	D	220	250	285	340
wiper	R1	93	105	120	147.5
	R2	41.5	47.5	55	68.75
	H	80.5	70.5	86	64.5
part number		7223.034.00	7223.035.00	7223.036.00	7223.037.00

Dimensions in mm. Subject to change without prior notice.

Spares

Wiperblades	for sizes/DN	length of wiperblade mm	silicone rubber part number	PTFE part number
	1/100	115	9468.020.00	9468.031.00
	2/125	140	9468.021.00	9468.032.00
	3/150	165	9468.022.00	9468.033.00
	4/200	215	9468.023.00	9468.034.00
Flexible Drive	for sizes/DN	part number		
	1/100	9223.014.00		
	2/125	9223.014.00		
	3/150	9223.016.00		
	4/200	9223.014.00		

Order data:

e.g. Lumiglas sight glass wiper type SW II BW, size 3, wiper blade silicone rubber.

If ordering with complete sightport assembly, please give the following additional information:

1. Sight glass assembly (DN/PN), materials
2. Type and size of the sight glass disc (borosilicate/sodalime)

