

## Full View Threaded Models Specifications

Over two years of engineering and design have resulted in a new industry standard for visual flow indicator technology.

Uncompromising levels of quality, safety and technological excellence are standard features in the complete line of L.J. Star Incorporated Full View Flanged Model visual flow indicators.

### Description

All full view threaded models in the L.J. Star Incorporated line of visual flow indicators are available in several application-specific configurations. Designed for 150 psi ( $\frac{1}{8}$ "-1"), 120 psi ( $1\frac{1}{2}$ " and 2"), these units are manufactured from either carbon steel or stainless steel. Impact deterrent shields are standard on full view threaded models; metal shields are also available.

### Styles

Full view threaded units are available in two styles designed to accommodate various mounting positions, fluid characteristics and flow rates:

- *Plain Style*  
May be installed in any position to observe fluid flow in any direction. These style indicators are usually employed to detect either the presence or absence of solutions, or to observe fluids for turbulence, color or clarity.
- *Drip Tube Style*  
This style is well suited for vertical lines with downward flow direction. These units are particularly recommended for applications characterized by low or intermittent flow rates, such as distillation processes.

### Standard Safety and Maintenance Features

- Investment cast surface finish
- Acrylic enamel coating (carbon steel unit)
- Teflon® gaskets Standard on stainless steel units
- Impact shield standard
- In-stock delivery



Full View Threaded Visual Flow Indicator

### Materials of Construction

- *Standard alloys*  
316 stainless steel; carbon steel
- *Optional alloys*  
Monel®; Hastelloy®; Alloy 20
- *Standard gasket materials*  
Neoprene; PTFE
- *Optional gasket materials*  
BUNA N; Viton®; silicone, graphite, and non-asbestos gaskets
- *Optional flow indicators*  
Flutter; Teflon Ball

### Ordering Information

Contact your nearest L.J. Star representative



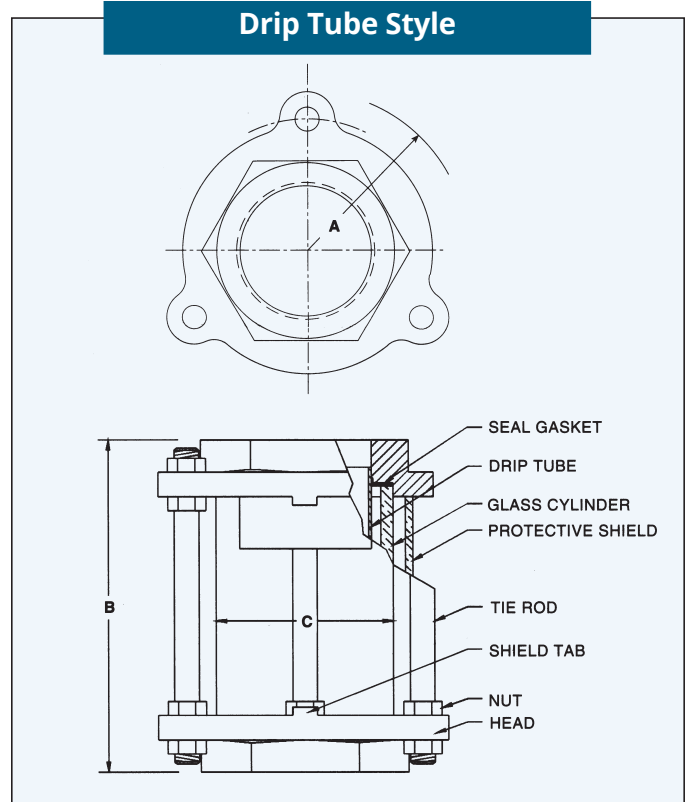
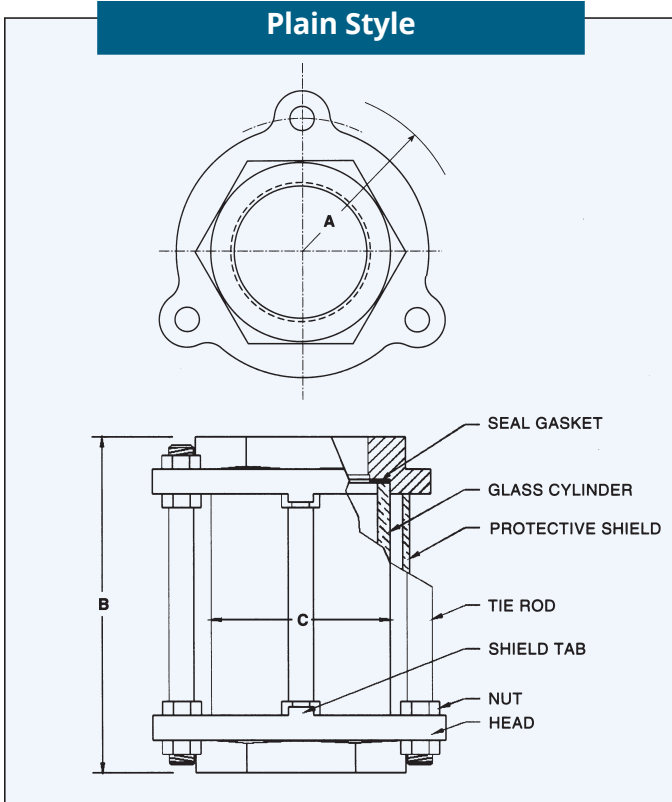

### Full View Threaded Model

Pipe Size	Dimension			Approx. Wt. (Lbs.)	Working Pressure (Psi.)
	A	B	C		
1/8"	2"	4-1/2"	1-3/4"	2	150
1/4"	2"	4-1/2"	1-3/4"	2	150
1/2"	2"	4-1/2"	1-3/4"	2	150
3/8"	2"	4-1/2"	1-3/4"	2	150
3/4"	2"	4-1/2"	1-3/4"	2	150
1"	2-1/4"	4-1/2"	2"	3	150
1-1/2"	2-5/8"	4-3/4"	2-1/2"	5	120
2"	2-7/8"	5-1/2"	3"	8	100

The specifications contained herein are subject to change without notice and any user of said specifications should verify from the manufacturer that the specifications are currently in effect. Otherwise, the manufacturer assumes no responsibility for the use of specifications which may have been changed and are no longer in effect.