

**Lumiglas® Stainless Steel Mini-Luminaire Series USL 01**

**ISO 9001**

DATA SHEET 02-0135 08/02

**For use with sightglass fittings**

This super-compact sight port luminaire is applicable for combination view/sight port (single port version) or separate light and sight port (dual-port version).

This powerful super-compact size luminaire is designed to give glare-free illumination with sight glass styles as follows:

- Circular weld-on sight glass series DIN 28 120 starting at DN 25
- Circular sight glass series ANSI Bolt-On starting at 1"
- Visual Flow Indicators starting at size 1/2"
- Circular weld-neck series MV starting at DN 50
- Sanitary clamp connection series MetaClamp starting at 1/2"

**External Diameter:** 24 mm

**Application:**

Ideal for lighting internals of small vessels such as bio reactors, laboratory mixers, filters, separators, pressure vessels, miniature tanks, pipelines and other normally enclosed systems in Non Ex hazardous areas.

Primarily intended for the Pharmaceutical, Bio-Tech and Food processing industries.

**Protection:**

Dust and water jet tight to NEMA 4, NEMA 4X, IP 65, and EN 60 529/DIN VDE 0470 Part 1.

**Operating Conditions:**

Independent of vessel internal pressure or vacuum; max. permissible ambient temperature 90° C (194° F).

**On no account may the luminaire be used as a closure for means of sealing of a (pressure) vessel (i.e. without a suitable sight glass fitting).**

**Electrical Data:**

The unit is factory fitted with 3 m of connecting cable.

**Power Supply:**

without integral push button

12 Volt halogen filament lamp 5 W, 2 pin socket G 4

with integral push button

24 Volt halogen filament lamp 20 W, 2 pin socket G 4

**Transformers:**

Transformers for 12 V or 24 V secondary voltage can be supplied on request.

**Integral Push Button:**

**The 20 W units come standard with integral push button switch.**

**Mounting Options:**

- Clip on mounting clamp for the Lumiglas-wiper assembly (type SW I).
- Hinged bracket for mounting onto retainers
- Sanitary clamp connection sizes 1/2" and up using MetaClamp® technology.



Lumiglas Stainless Steel Mini-Luminaire, Series USL 01 with hinged bracket.

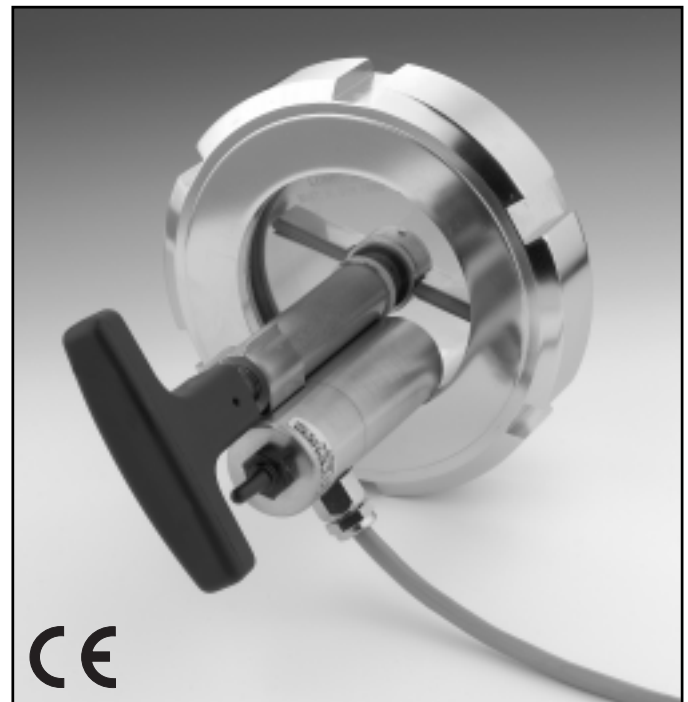

Lumiglas Stainless Steel Mini-Luminaire, Series USL 01 with mounting clamp fitted on a screwed sightglass fitting with Lumiglas sightglass wiper type SW I.



**Dimensions of the Lumiglas Stainless Steel Mini-Luminaire, Series USL 01:**

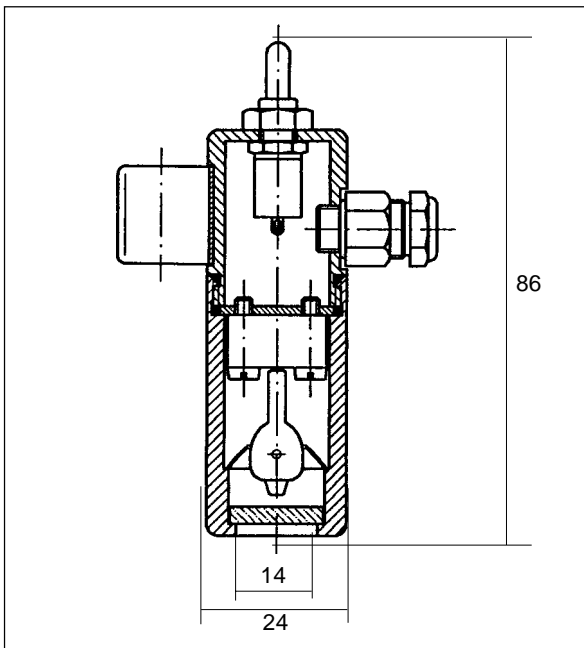

**Material and Parts:**

- Body and head: 303 stainless steel (1.4305).
- Mounting bracket: Stainless steel (both for hinged version and SW1 wiper clamp).
- Connecting cable: 3 m (3 x 0.5 mm<sup>2</sup>).
- Weight: appx. 0.150 kg.

**Power Connecting Data:**

Lumiglas Stainless Steel Mini-Luminaire, USL 01			
Item	Model USL 01	Part No.	Supply V
1	(12 V) 5 W without p. button	USL01-L5	12
2	(24 V) 20 W with push button	USL01-H20	24

Replacement Parts		
Halogen Filament Lamps		
Socket	Power	Part No.
G 4	12 V/5 W	BLB-L5-G4N
G 4	24 V/20 W	BLB-H20-G4N

**Mounting Bracket:**

- mounting clamp
- hinged bracket Cat. No. 3540.002.00

**Ordering Specifications (example):**

- Lumiglas Stainless Steel Mini-Luminaire, Series USL 01, 24 V/20 W with push button, Part No. USL01-H20
- Hinged mounting bracket, mounting clamp or sanitary connection (include connection size)

**Example of fastening:**



Lighting port assembly, showing Lumiglas Stainless Steel Mini -Luminaire, Series USL 01, with hinged bracket fitted to screwed sightglass (MV 50).



Light port assembly using the Lumiglas Stainless Steel Mini-Luminaire, Series USL 01, with Metaglas Metaclamp.

All dimensions in mm unless stated otherwise. Subject to change without prior notice