

Stainless Steel Lumiglas Luminaire Series ESL 25-Ex

ISO 9001

DATA SHEET 02-0210 7/01

For use with sight glass fittings

This "Ex" rated luminaire is ideally suited for use on integral sight/light glass (single port) or separate sight and light glass (dual port) systems.

Super compact yet with high light output:

Glare free illumination; fits bolted sight glass assemblies similar to DIN 28120/ 28121 as well screwed sight glass assemblies similar to DIN 11851 and visual flow indicators. Sizes, depending on style, from DN 25 upward.

Exceptionally large light exit thanks to carefully designed screwed lens assembly.

Applications:

Illumination of internals of visual flow indicators, pipelines, laboratory mixers, bio-reactors, as well as internals of storage tanks, reactors and other normally sealed process vessels in explosion hazardous zones, zone 1 and 2, to IEC 79-10, especially for use in pharmaceutical and food in-dustry.

Protection: Dust and waterjet tight, IP65 to EN 60529/DIN VDE 0470 part 1. NEMA types: 4 and 4X

Operating Conditions: Independent of Vessel Internal Pressure/Vacuum.

Lumiglas luminaires of this series are designed for ambient temperatures of up to 60° C.

EC Type test certification: DMT 98 ATEX E 039 X

Special Conditions: Connection of the cable gland elements may only be made with enclosures conforming to standardized ignition group in accordance with EN 50014, Section 1.2. The models listed under item ref.no. 15.3.2, which are required to operate at a higher temperature, must be used with a certified cable-entry gland and a cable which can accept an operating temperature of at least 110° C.

Ignition Group: EEx d "pressure tight enclosure" to DIN EN 50018

Explosion Group: IIC (all explosion classes)

Temperature Class: up to T6 (depending on wattage)

Electrical Data and Components: Conforming to EG production type test certification

Supply: AC/DC depending on luminaire model

Operating supply:

Without integral transformer:

12 V... Halogen filament lamp 5 W, 10 W, 20 W

24 V... Halogen filament lamp 20 W

With integral transformer:

PTC-protected, otherwise temperature fuse

230 V... Halogen filament lamp 12 V/5 W, 10 W

120 V... Halogen filament lamp 12 V/5 W, 10 W

Filament Lamp Socket: see separate table on page 2

Installation Instruction and Examples: see page 3

Accessories:

- Fastening: Hinged bracket, stainless steel; adapter flange, stainless steel
- Lens ring spanner for opening luminaire
- EEx Time delay switches, in separate enclosures, for automatic limitation of lighting
- Connecting Cable



Stainless Steel Lumiglas Luminaire Type ESL 25-Ex¹



Stainless Steel Lumiglas Luminaire Type ESL 25-Ex with hinged bracket fastening, plain design, polished.

¹ Generally the luminaire structure design that will be delivered if not specified otherwise.

Dimensions and Electrical Data for Lumiglas Luminaires Series ESL 25-Ex

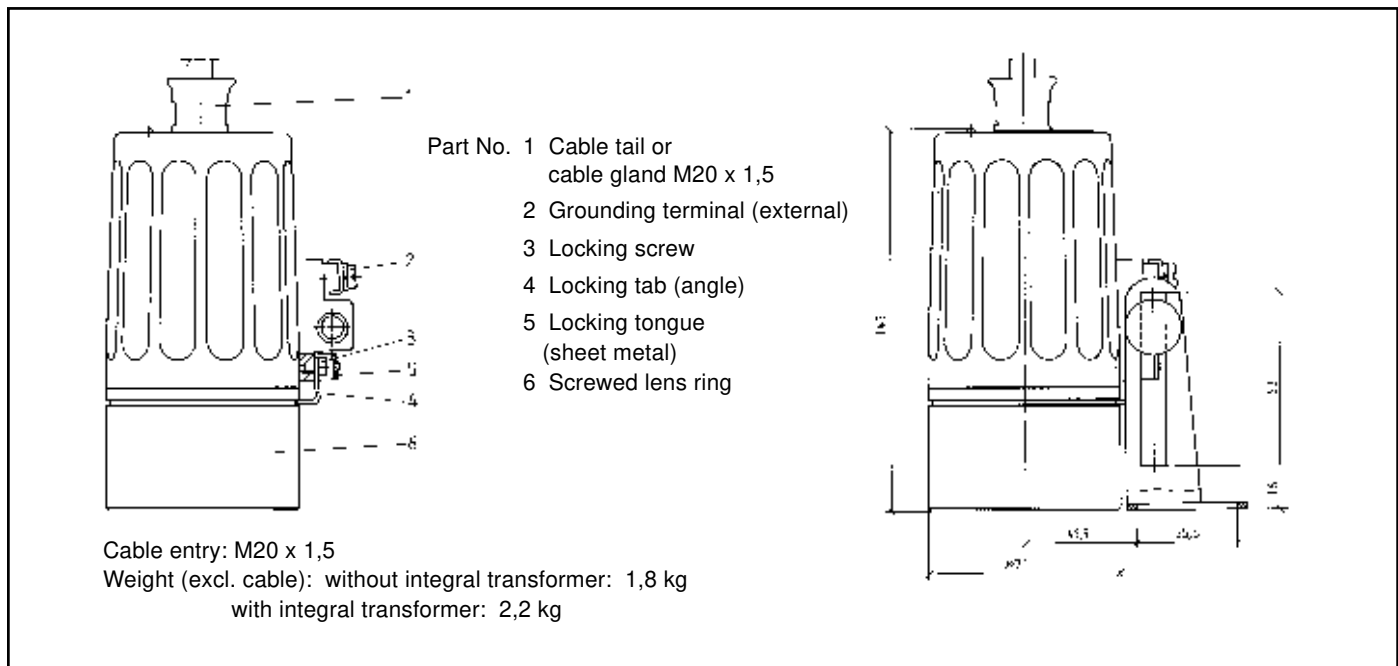

Parts, Materials and Finish:

- Luminaire body: Stainless steel 1.4301(304 SS), polished
- Fastening bracket: Stainless steel (see 'accessories')

Connecting Data

- a) ESL 25-Ex - with integral cable tail
 b) ESL 25-Ex/1 - without cable

Item	Type ESL 25-Ex	Cat. No. a) ESL 25-Ex with cable	Cat. No. b) ESL 25-Ex/1 without cable	Supply V	Integral Transform.	Halogen Lamp			Temp. Class at max.	
						socket	voltage	Cat.No.	40 °C	60 °C
1	(12 V) 5 W	3540.902.90	3540.922.90	≈ 12	without	G4	12 V/5 W	3232.221.00	T 6	T 4
2	(120 V/12 V) 5 W	3540.904.90	—	≈ 115	with	G4	12 V/5 W	3232.221.00	T 6	T 4
3	(230 V/12 V) 5 W	3540.906.90	—	≈ 230	with	G4	12 V/5 W	3232.221.00	T 6	T 4
4	(12 V) 10 W	3540.907.90	3540.927.90	≈ 12	without	G4	12 V/10 W	3232.224.00	T 5	T 4
5	(120 V/12 V) 10 W	3540.908.90	—	≈ 120	with	G4	12 V/10 W	3232.224.00	T 5	T 4
6	(230 V/12 V) 10 W	3540.910.90	—	≈ 230	with	G4	12 V/10 W	3232.224.00	T 5	T 4
7	(12 V) 20 W	3540.912.90	3540.932.90	≈ 12	without	GU4	12 V/20 W	3232.258.00	T 4	T 3
8	(12 V) 20 W	3540.914.90	3540.934.90	≈ 12	without	G4	12 V/20 W	3232.229.00	T 4	T 3
9	(24 V) 20 W	3540.916.90	3540.936.90	≈ 24	without	G4	24 V/20 W	3232.222.00	T 4	T 3

Ordering Information:

example:

Lumiglas Luminaire Type ESL 25-Ex (230 V/12 V) 5 W
 EEx d IIC T6 with 2 m (...) Connecting Cable
 Cat. No.: 3540.906.90
 with hinged bracket, Cat. No. 0354.019.00

example:

Lumiglas Luminaire Type ESL 25-Ex/1(24 V) 20 W
 EEx d IIC T4
 Cat. No. 3540.936.90

Accessories and spare parts: see page 4

LJSTAR

PO Box 1116 • Twinsburg, OH 44087 • (330) 405-3040 • Fax 405-3070

I N C O R P O R A T E D

E-mail: view@ljstar.com • Website: www.ljstar.com

Installation Instruction:

The easiest way of setting up the luminaire is by using the purpose designed securing brackets available:

Ensure also that, before installation, you read the Information Sheet "Important note for users of sight glass fittings .."

On circular sight glasses and on flow indicators the hinged bracket secures the luminaire to the cover flange face. In the case of the screwed sight glass the luminaire is secured to the slotted cover nut.

The Lumiglas Luminaire ESL 25-Ex suits the following fitting sizes:

- a) circular sight glass style DIN 28120: DN 25...
- b) circular sight glass style DIN 28121: DN 40...
- c) flow indicators: DN 50
- d) screwed sight glass style DIN 11851:
 - DN 65 using the separate upstand adapter.
 - DN 80 upwards using the hinged bracket.

Hinged bracket:

Secure bracket on bolt circle of flange face using the M8 screw provided or by welding it on.

Adapter flange:

Adapter flange fits between glass disc and slotted cover nut (DIN 11851):

- Lay gasket provided between upstand flange and glass.
- Tighten cover nut.
- Slide luminaire into upstand.
- Tighten set screws on adapter flange.

Problem free electrical connection:

a) ESL 25-Ex - with integral cable tail:

- Cable is resin cast into EEx d flared cable entry gland.
- Luminaire is ready wired internally for operation.
- The external safety terminal (2) requires connection to a suitable earthing point.
- Unsupported cable length should not exceed 1 m.
- Caution! If the cable is to be changed e. g. for a different length, ensure internal wiring and cable gland internal lock nut are first loosened.

b) ESL 25-Ex/1- without cable:

- Cable connected through EEx d cable entry screwed gland unit.
- Screwed cable entry gland supplied is suitable for all non-armored cable whereby proper seal is assured between gland and outer cover of cable.
- Select correct cable to suit screwed gland assembly (1).
- Unscrew lens ring (6) using special key (see "lamp exchange").
- Unscrew cable gland (1).
- Pass cable through gland into luminaire body and secure cable cores to terminals.
- Tighten cable gland (1).
- Refit lens ring (6) and rotate until tight (see „lamp exchange“).
- Connect external safety terminal (2) to suitable earthing point.

Connecting cable options:

a) works fitted: connecting cable (standard length 2 m) with integral pressure tight resin cast threaded cable entry and lock nut fitted one end. Alternative lengths available on request: 5, 10, 20 m.

b) no works fitted cable: select cable suitable for cable gland assembly (M20 x 1,5).

At ambient temperatures greater than 40° C use heat resistant cable e. g. 4GMH4G-J3x1,5mm2.

Easy lamp exchange - thanks to lens ring design:

- Switch off power.
- Wait for period shown on identity plate.
- Loosen locking screw (3) so releasing locking tab (angle) (4) to lens ring (6).
- Using only the correct key, unscrew lens ring (6).
- Withdraw defective lamp (2 pin).
- Replace with new lamp (use only genuine original parts) holding it with protective material (not bare fingers) and pressing home carefully into 2 pin socket.
- Replace and tighten lens ring (6) until pressing against 'O'-ring.
- Ensure tab (4) engages in its notch so that lens ring (6) is locked in position.
- Retighten locking screw (3).
- Switch back on.

Installation examples:



As lighting port, fitted to sight glass style DIN 28120, DN 50.



As lighting port, fitted to DN 65, dairy style unit, using adapter flange.

Accessories and parts for Lumiglas Luminaire ESL 25-Ex

Part	Cat. No.		
Luminaire fastening - Hinged Bracket	0354.019.00		
Luminaire fastening - Upstand	1356.007.00		
Lens ring with reflector	1774.051.00		
Lens ring without reflector	1774.050.00		
'O' ring seal (Viton)	0862.073.00		
Fitting key / claw spanner	6816.001.00		
Lamp socket, G4 (2 pin)	1202.011.00		
Lamp socket, GU4 (2 pin)	1202.023.00		
Cable entry gland assembly	9103.105.00		
		Lamp Maker	Maker's Ref.
Halogen filament lamp 12 V, 5 W	3232.221.00	Osram	64405 S
	"	Philips	13283
	"	BLV	104510
Halogen filament lamp 12 V, 10 W	3232.224.00	Osram	64415 S
	"	Philips	13284
	"	BLV	104630
	"	Sylvania	21990
Halogen filament lamp 12 V, 20 W	3232.229.00	Osram	41900 SP
Halogen filament lamp 24 V, 20 W	3232.222.00	Osram	41930 SP
Halogen filament lamp (coldlight) 12 V, 20 W	3232.258.00	Sylvania	22336 NSP
	"	"	22338 FL
	"	Philips	0622112 FTB
	"	"	0622132 FTD

All dimensions in mm unless stated otherwise. Subject to change without prior notice.