

Lumiglas Luminaire Stainless Steel Series ESL 26-Ex II 2G EEx de IIC T3/T4

ISO 9001

DATA SHEET 02-0230 06/05

- for mounting on sight glass fittings -

A stand alone unit which is ideal for use as combined sight/light glass (single port) arrangement or with separate ports for viewing and lighting (dual port).

Compact yet powerful:

Glare free illumination; for use with circular sight glass fitting styles to DIN 28120, Bolt-ons; MV weld-neck sight glass fittings DIN 11851 and visual flow indicators.

Exceptionally large light exit due to specially designed screwed lens assembly.

Application:

For illumination of internals of normally closed vessels such as storage tanks, columns, reactors, mixers as well as visual flow indicators in Explosion Hazardous areas, Zone 1 and 2 according to IEC 79-10; suitable for use in food processing.

Protection: Dust and waterjet proof to IP65 EN 60 529 / DIN VDE 0470 part 1. NEMA Types: 4 and 4X

Operating conditions: Totally independent of vessel internal pressure/vacuum.

Lumiglas Luminaires of this series are approved for use in ambient temperatures of up to 60° C.

EG Type test certificate: DMT 97 ATEX E 004

Ignition protection class:

EEx de Flameproof Enclosure and Increased Safety (terminal box) to DIN EN 50 018 and DIN EN 50 019 / VDE 0170/0171.

Explosion group: IIC (includes groups IIA & IIB)

Temperature Class: up to T4 (depending on power)

Electrical data and lamps:

Complies with DMT certificate, power supply AC or DC, dependent on luminaire type.

Supply voltage:

without integral transformer:

- 12 V...Halogen filament lamp 20 W, 35 W or 50 W
- 24 V...Halogen filament lamp 20 W or 50 W
- 230 V...Halogen filament lamp 40 W or 50 W

with integral transformer (PTC-secured):

- 230 V...Halogen filament lamp 12 V / 20 W
- 240 V...Halogen filament lamp 12 V / 20 W
- 120 V...Halogen filament lamp 12 V / 20 W

Lamp socket: see separate table

Fitting instruction: see page 3

Accessories:

- mounting: stainless steel hinged bracket, adapter flange for MV or MetaClamp for sanitary fittings
- claw spanner for lens ring to open/close luminaire
- integral 'Lumiglas timer' 5 minutes time delay to 'off' (data sheet 09.01)
- EEx separate external push button time delay switch for timed illumination (data sheet 02-0268)
- connection cable



Stainless Steel Lumiglas Luminaire Type ESL 26-Ex with terminal box and hinged bracket fastening

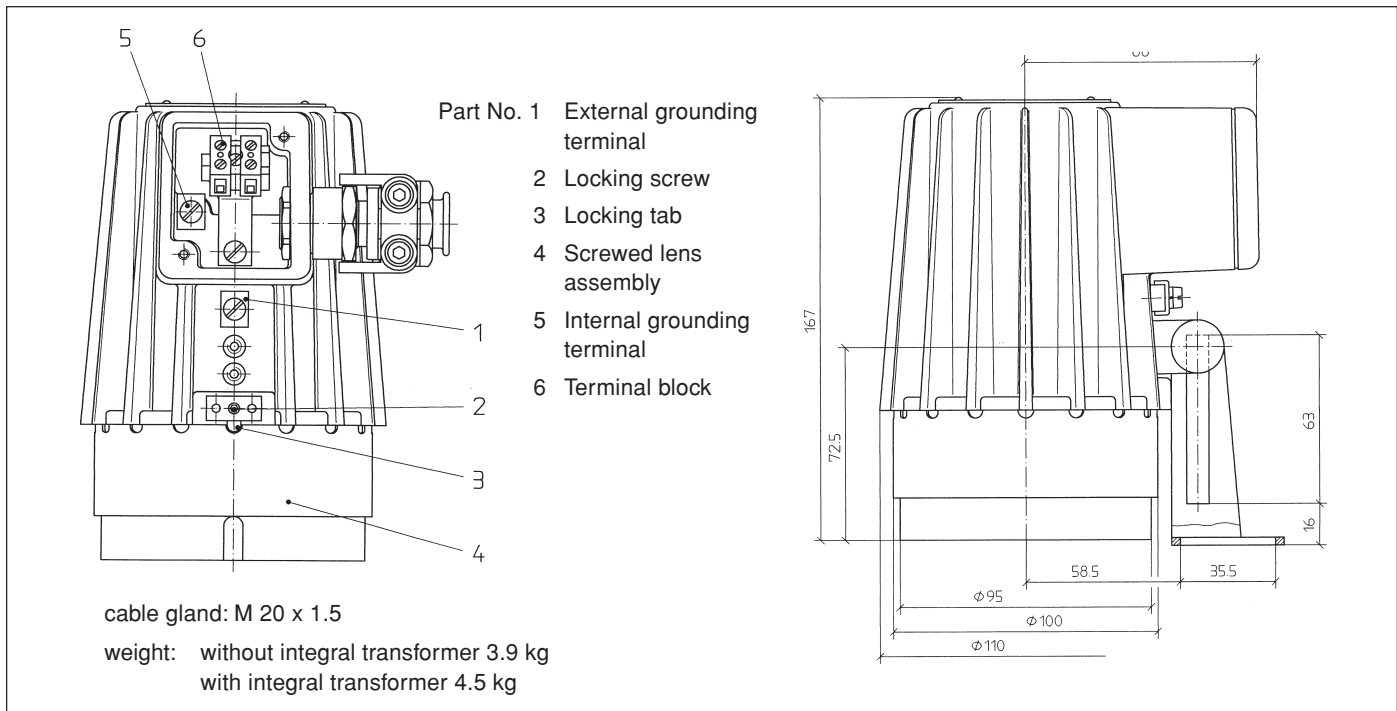

Parts, construction and materials:

- luminaire body: stainless steel 1.4404 (316L), polished
- mounting bracket: see under accessories

Item	Type ESL 26-Ex	Part No.	Supply Voltage	Integral Transformator	Halogen Filament Lamp			Temp. Class at max.	
					socket	voltage	Part No.	40 °C	60 °C
1	(12 V) 20 W	26E2-A1CNANNN	12	-	GY6.35	12 V/20 W	BLB-L20GYN	T 4	T 4
2	(24 V) 20 W	26E2-A2CNANNN	24	-	G4	24 V/20 W	BLB-H20GYN	T 4	T 4
3	(120 V/12 V) 20 W	26E2-A3CNANNN	120	with	GY6.35	12 V/20 W	BLB-L20GYN	T 4	T 4
4	(230 V/12 V) 20 W	26E2-A4CNANNN	230	with	GY6.35	12 V/20 W	BLB-L20GYN	T 4	T 4
5	(240 V/12 V) 20 W	26E2-A5CNANNN	240	with	GY6.35	12 V/20 W	BLB-L20GYN	T 4	T 4
6	(12 V) 35 W	26E2-A1ENANNN	12	-	GY6.35	12 V/35 W	BLB-L35GYN	T 4	-
7	(230 V) 40 W	Call Factory	230	-	E14	230 V/40 W PAR 20	Call Factory	T 3	-
8	(12 V) 50 W	26E2-A1FNANNN	12	-	GY6.35	12 V/50 W	BLB-L50GYN	T 3	-
9	(24 V) 50 W	26E2-A2FNANNN	24	-	GY6.35	24 V/50 W	BLB-H50GYN	T 3	-
10	(230 V) 50 W	26E2-A4FNANNN	230	-	E27	230 V/50 W PAR 20	BLB-E50EF	T 3	-

Ordering information:

example: Lumiglas Luminaire Type ESL 26-Ex, 230 V/12 V, 20 W
(please advise if luminaire to be supplied with flood reflector)

Accessories and spare parts: see page 4

Installation Instructions:

The easiest way of installing the luminaire is by using the mounting bracket available:

Before fitting, please refer to our leaflet entitled 'Important Note for Users of Sight Glass Fittings, Toughened Glasses and Luminaires'.

On circular sight glass units and flow indicators the luminaire is bolted to the cover flange by the hinged bracket.

With MV neck-weld sight glass units, the bracket is fastened to the slotted cover nut.

Luminaire model ESL 26-Ex fits the following nominal sizes:

- a) Circular fittings to DIN 28120, sizes DN 50 and larger
- b) Bolt-on sight windows, sizes 2" and larger
- c) Visual flow indicators, sizes 2" and larger
- d) MV weld-neck fittings similar to DIN 11851:
 - sizes DN 65, 80, 100: separate adapter collar
 - sizes DN 80, 100, 125: hinged bracket
 - sizes DN 80 and 100: alternatively separate adapter collar or hinged bracket
- e) Sanitary MetaClamp®, sizes 1" and larger

Hinged bracket:

The bracket is fastened by means of welding or the M 8 bolt supplied and the blind tapped hole on the required bolt circle.

Adapter flange:

The flange is fastened on the slotted cover nut, (DIN 11851), welded or bolted.

Problem free electrical connection:

- Remove terminal box lid.
- Loosen socket screws on cable gland clamp (which serves to prevent accidental pull out or rotation of cable).
- Insert cable and retighten screws.
- Connect cable cores to 'Ex' terminals (6); grounding core to inner terminal (5).
- Exterior grounding terminal (1) must be connected to separate grounding point in plant.
- Fit lid gasket correctly and close lid.

Easy lamp change - due to lens ring design:

- Switch power OFF.
- Allow to cool for requisite period shown on identification plate.
- Loosen socket screw (2) on locking tab (3) securing screwed cover glass barrel (4).
- Using correct claw spanner, unscrew cover glass.
- Remove defective lamp by pulling out (2-pin) or unscrewing (E14/E27).
- Holding new lamp (only genuine specified component) with protective material (not bare fingers) carefully fit into 2-pin socket and firmly press home, or screw in fully, making sure final position is correct and centered.
- Refit screwed cover glass (4) to seal against O-ring and tighten sufficiently to engage safety tab (3) in nearest locking notch on cover glass barrel.
- Retighten screw (2).
- Reconnect power.

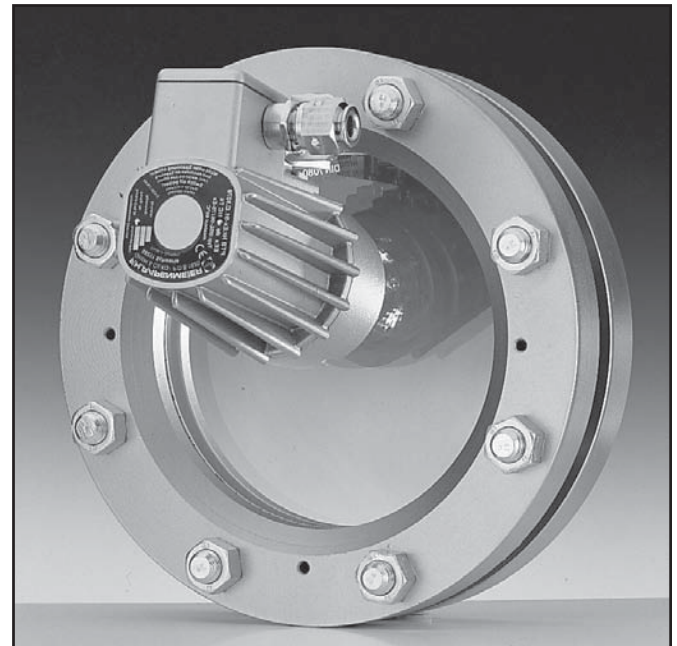

Stainless Steel Lumiglas Luminaire Type ESL 26-Ex installed by a hinged bracket on the cover flange of a circular fitting DIN 28120, forming a combined sight/light port.

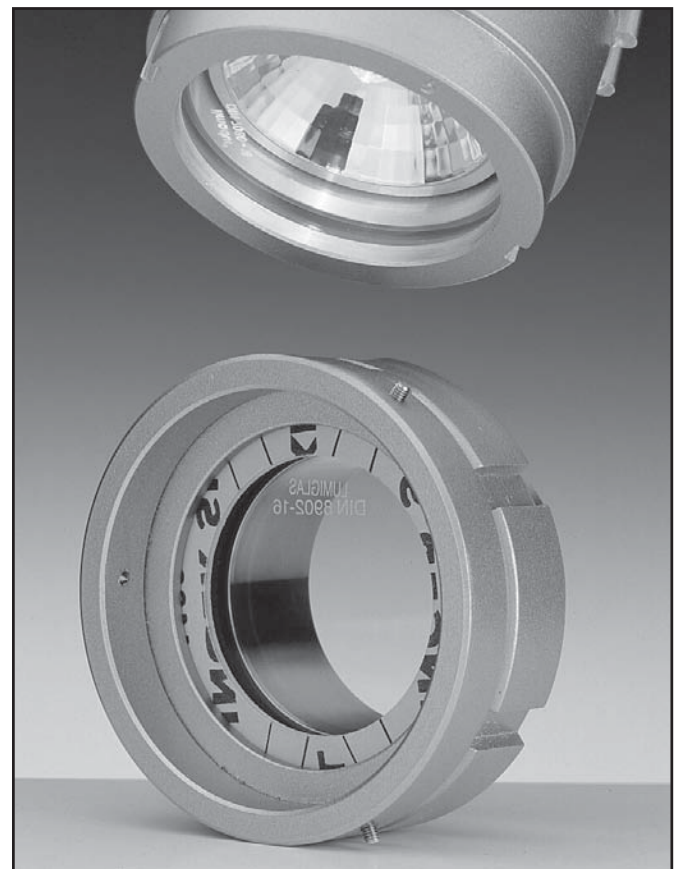

Installation with adapter flange on a MV neck-weld sightglass fitting, forming a light port

Accessories and parts for Lumiglas Luminaire ESL 26-Ex

Part	Cat. No.
Luminaire fastening (Hinged Bracket)	0354.016.00
Luminaire fastening (Adapter)	1356.015.00
Lumiglas-Timer	works fitted
Lens ring with reflector	1774.044.00
Lens ring without reflector	1774.043.00
Reflector, spot	5904.047.00
Reflector, flood	5904.048.00
'O' ring seal (Viton)	0862.039.00
Fitting key	6805.001.00
Lamp socket, G4 (2 pin)	1202.011.00
Lamp socket, GY6.35 (2 pin)	1202.012.00
Lamp socket, E27	1202.019.00
Lamp socket, E14	1202.022.00
Flat seal cover	0854.038.00
Flared cable gland (M 20x1.5)	9108.008.00

All dimensions in mm unless stated otherwise.
Subject to change without prior notice.