

Lumiglas Luminaire Series USL 05-EX EEx d II C T3 ... T6

ISO 9001

- for use with sightglass fittings -

DATA SHEET 02-0200 08/02

Application:

This super-compact luminaire can be used for integral light/sight port (single flange version) or separate light and sight ports (dual flange version) to illuminate the internals of through-flow indicators, pipelines, laboratory mixers and other vessels and reactors which are normally closed. This model is intended for use in all Ex Hazardous Areas. The unit is suitable for food processing. The luminaire must never be inserted into a vessel wall as a sealing element, i.e. without appropriate sightglass disc and fitting.

Sightglass Styles and Size:

This powerful, super-compact luminaire is designed to give glare free illumination in combination with circular sightglasses of the following styles:

- bolted circular flanges acc. DIN 28120/28121 or similar styles
- circular screwed flanges acc. DIN 11 851
- visual flow indicators (tubular or opposed flat glass disc)
- sanitary clamp connection, 1" and larger

Size:

The luminaire is suitable for sightglasses DN 25 and larger.

Ambient Condition Operating Range:

This unit is approved for operation at ambient temperatures up to 60°C. Certificates: PTB Nr. Ex- 85/2152, 85/2153, 86/2056, 87/2052, 87/2163, 87/2164. The unit is independent of internal vessel pressure or vacuum.

Protection:

Dust and waterjet tight to IP 65 and EN 60598, certificate available.

Ignition protection class:

EEx d "flame proof enclosure" acc. DIN EN 50 018/VDE 0171.

Temperature class:

up to T6 (depending on power intake)

Explosion class:

IIc (all explosion classes)

Electric data, lamp sockets and lamps

According to PTB conformity certificate, AC or DC depending on lamp type, please see table overleaf

Power supply:

- with built-in transformer
 - supply 220 or 240 V; halogen lamp 12V/5 W
 - supply 120 V; halogen lamp 12V/5 W
- without built-in transformer
 - supply 12 V halogen lamp 5W or 10W
 - minispot halogen reflector lamp 20W
 - supply 24 V minispot halogen reflector lamp 20W

Installation instructions and examples please see pages 3 + 4

Additions:

- installation set: hinged bracket made of stainless steel
 adapter/upstand flange made of aluminium
- special claw spanner for opening/tightening of the lens ring



Lumiglas luminaire USL 05-EX on hinged bracket fastening



Lumiglas luminaire USL 05-EX, tilted back to give access to lens unit

Dimensions and Connection Data for Lumiglas Luminaire type USL 05-EX

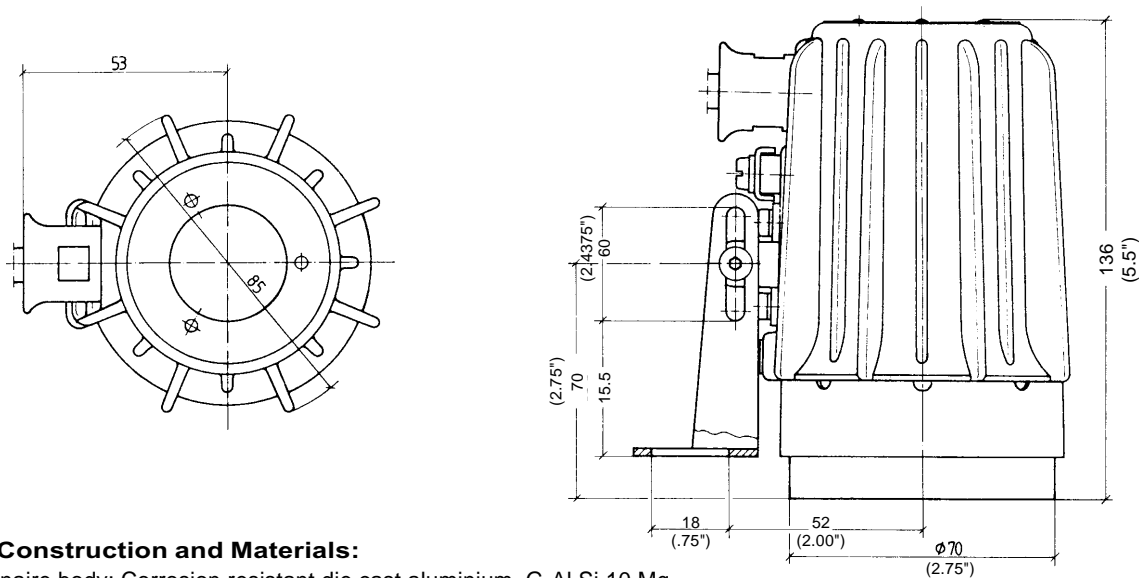

Parts, Construction and Materials:

- Luminaire body: Corrosion resistant die cast aluminium, G-Al Si 10 Mg
- Cable gland: with pressure tight resin cast (potted) cable tail, 6.5 ft., Siemens 4GMH4G-J 3 x 1,5 mm²
- Ground terminals: ready connected inside housing; extra ground terminal outside on housing
- Lens: Bonded unit of aluminium ring and glass, Viton sealing
- Fastenings: See under "Spares"
- Weight: 1.5 lb. (2 lb.z with built-in transformer)

Ordering Information:

Please state for example: Lumiglas luminaire USL 05-EX, type SL - H5d 240/12V

All dimensions in mm unless stated otherwise Subject to change without prior notice

| Pos. | Supply Voltage | Power Intake W | Luminaire Type | Built-in Transformer with PTC fusing V sec. | Halogen Lamp Type | Voltage | Wattage | Socket |
|---|----------------|----------------|----------------|---|-------------------|---------|---------|--------|
| Temperature Class up to T3 / 60°C or up to T4 / 40°C ambient temperature depending on conformity certificate | | | | | | | | |
| 1 | 24 ~ | 20 | SL-H 20d | no | halogen | 24 | 20 | G4 |
| 2 | 12 ~ | 20 | SL-H 20d | no | halogen | 12 | 20 | G4 |
| Temperature Class upto T3 / 60°C ambient temperature depending on conformity certificate | | | | | | | | |
| 3 | 240~ | 5 | SL-H 5d | yes, 12 V sec | halogen | 12 | 5 | G4 |
| 4 | 220~ | 5 | SL-H 5d | yes, 12 V sec | halogen | 12 | 5 | G4 |
| 5 | 12 ~ | 5 | SL-H 5d | no | halogen | 12 | 5 | G4 |
| 6 | 12 ~ | 10 | SL-H 10d | no | halogen | 12 | 10 | G4 |
| Temperature Class up to T5 / 40°C ambient temperature depending on conformity certificate | | | | | | | | |
| 7* | 12 ~ | 10 | SL-H 10d | no | halogen | 12 | 10 | G4 |
| Temperature Class up to T6 / 40°C ambient temperature depending on conformity certificate | | | | | | | | |
| 12 | 240~ | 5 | SL-H 5d | yes, 12 V sec | halogen | 12 | 5 | G4 |
| 13 | 220~ | 5 | SL-H 5d | yes, 12 V sec | halogen | 12 | 5 | G4 |
| 14 | 12 ~ | 5 | SL-H 5d | no | halogen | 12 | 5 | G4 |
| 15 | 120~ | 5 | SL-H 5d | yes, 12 V sec | halogen | 12 | 5 | G4 |

* on request

LJSTAR

PO Box 1116 • Twinsburg, OH 44087 • (330) 405-3040 • Fax 405-3070

INCORPORATED

E-mail: view@ljstar.com • Website: www.ljstar.com

USL 05-EX Installation instructions

General:

The unit is usually bolted with its stainless steel hinged bracket to the respective sightglass assembly, such as the cover flange of a bolted circular sightglass or a through flow indicator or the slotted cover nut of a screwed flange sightglass.

Lumiglas USL-05 EX can be used for the following sightglasses and larger sizes:

- bolted circular flanges Model DIN 28120, DN 25
- circular screwed flanges Model DIN 28121, DN 40
- visual flow indicators
- circular screwed flanges style Series MV
 - on DN 65 sightglasses the luminaire is installed with an adapter flange
 - on sightglasses DN 80 or larger a hinged bracket is used
- sanitary clamp connection, 1" and larger

Hinged bracket installation:

The hinged backed is fastened on the flange cover by means of the M6 screw which comes with the Lumiglas unit.

Adapter flange installation:

The adapter flange is shaped to fit around the luminaire lens ring. It is installed between cover nut and glass of a sightglass fitting Series MV. Please ensure that:

- an appropriate flat gasket is fitted between sightglass disc and adapter flange
- the cover nut is firmly tightened

Then insert the luminaire into the adapter flange and tighten the lateral locking screws evenly

Electrical Connection:

The cable is readily fitted and internally connected at the factory. In the gland the cable is cast into solid resin to provide a pressure tight cable entry. Note: Never try to open the cable gland, as this would destroy the resin sealing and eliminate the explosion-protection of this luminaire. If you want to replace the cable, disconnect the internal terminals and then unscrew the internal locking screw before screwing cable gland with cable off the luminaire housing. Connect the external ground terminal (18) to the main ground, and connect the power cable leads to the main power system by means of an explosion proof switch or terminal box. The cable should be supported at a point of 3 ft. meter from the cable entry.

Lamp Change:

- switch off the luminaire and disconnect the power supply
- wait for the cooling time period as stated on the luminaire's label
- loosen securing screw 11 to release tab 9
- use the special claw spanner to loosen the notched lens ring 4 and remove lens ring
- replace halogen lamp, ensure bare fingers do not touch the glass
- refit lens ring, tighten firmly with special claw spanner, so that tab 9 meets one of the lens ring's notches
- tighten securing screw 11
- reconnect power

Spares

| Item | No |
|--|---------------|
| - lamp mounting (hinged bracket) | 1.0354.014.91 |
| - lamp mounting (adapter flange) | 2.1356.007.34 |
| - lens and ring unit | |
| - with reflector, for SL-H 5 d / SL-H 10 d | 1.1774.022.91 |
| - without reflector, for SL-H 20 d | 1.1774.030.91 |
| - "O" ring (Viton) | 5.0862.036.00 |
| - transformer prim. 240V, sec. 10.5 V | 1.8711.001.00 |
| - transformer prim. 220V, sec. 10.5 V | 1.8711.002.00 |
| - cable gland with 2 m connection cable | 1.1084.001.91 |
| - lamp socket G 4 (2-pin) | 5.1202.011.00 |
| - minispot halogen reflector lamp 12V/20W | 5.3232.229.00 |
| 24V/20W | 5.3232.222.00 |
| - halogen lamp 12V/5W | 5.3232.221.00 |
| 12V/10W | 5.3232.224.00 |
| - special claw spanner (for lens ring) | 5.6816.001.00 |

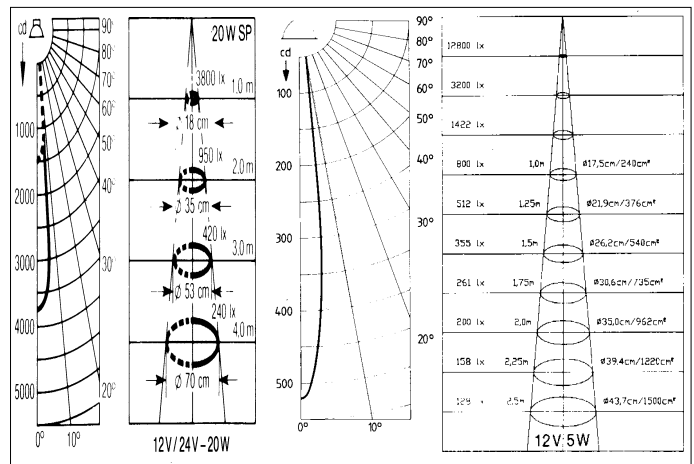

Light spreading (cd) and illumination grade (lx)

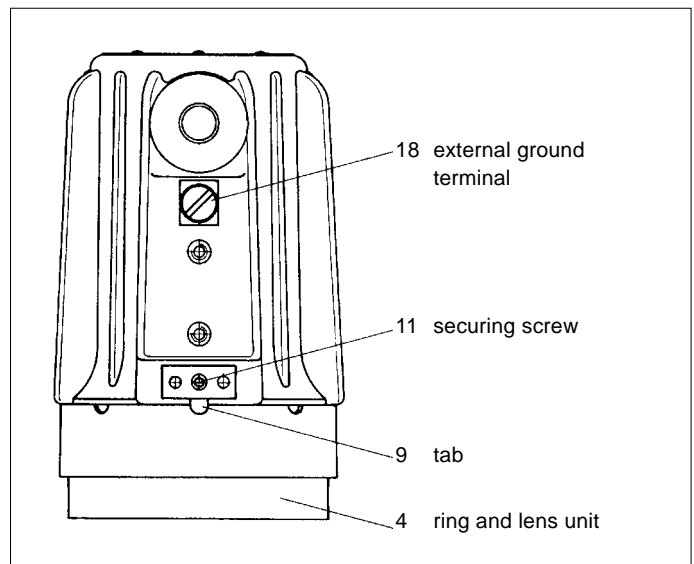

Application examples



Lumiglas USL 05-EX mounted on a Model DN 28 120 for a combination light/sightport



Lumiglas USL 05-EX, on hinged bracket, installed as light port on a bolted flange sightglass fitting Model DIN 28 120 DN 50



Lumiglas USL 05-EX with adapter flange, installed as light port on a screwed flange sightglass fitting DN 65



Lumiglas USL 05-EX on a visual flow indicator

ISO 9001 QA CERTIFICATE
 GERMAN MANUFACTURER:
 F.H. PAPANMEIER AWARDED QA APPROVAL CERTIFICATE



LJSTAR
 INCORPORATED

PO Box 1116 • Twinsburg, OH 44087 • (330) 405-3040 • Fax 405-3070

E-mail: view@ljstar.com • Website: www.ljstar.com